

DETAILS AT THE OPENING OF SHAFT

Basic Wind speed-150 kmph

SCHEME:
120 K.L OHBR
25.00M Staging

 AEE
 DEE
 EE
 //Approved//

 Chief Engineer-II
 RWS&S, Gollapudi
 Vijayawada.

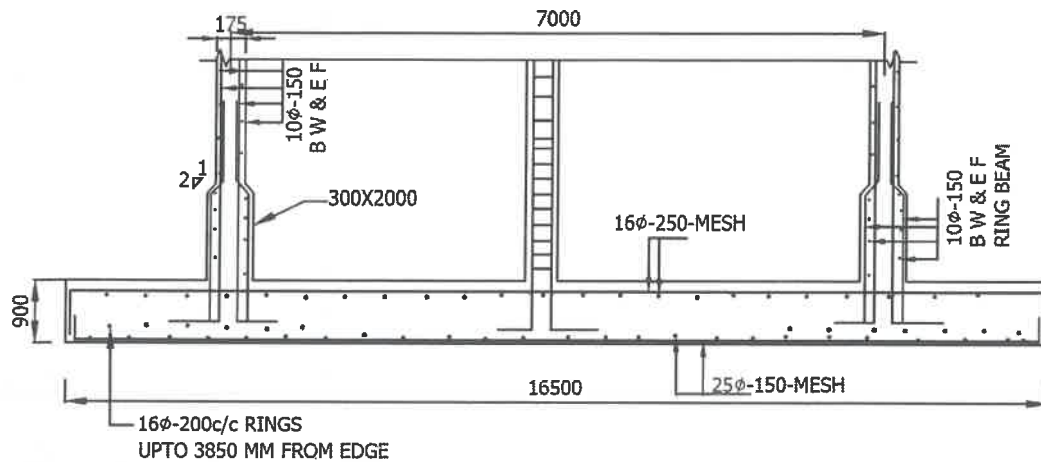

SECTIONAL ELEVATION

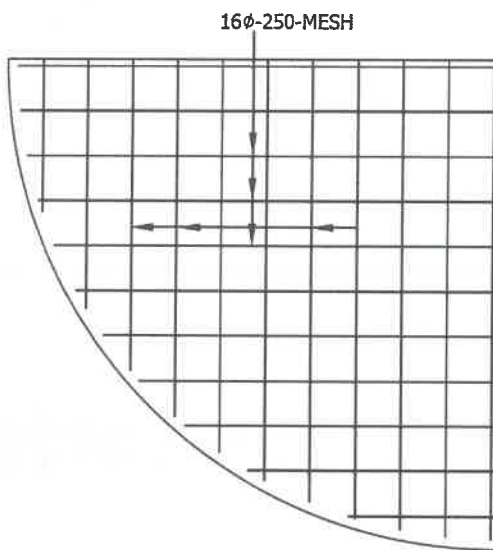

TOP REINFORCEMENT

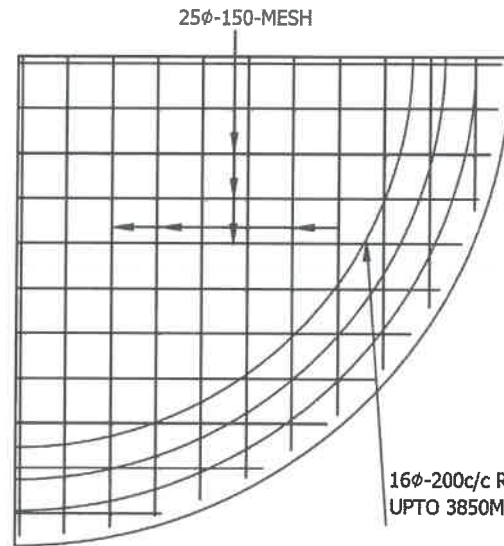

BOTTOM REINFORCEMENT

NOTE:

1. GRADE OF CONCRETE : M30
2. GRADE OF STEEL : Fe415
3. BASIC WIND SPEED : 150KMPH
4. DEPTH OF FOUNDATION: 2.50m BELOW GROUND LEVEL UPTO TOP OF RAFT
5. ALL DIMENSIONS ARE IN "MM"
6. S B C OF SOILL-5T/SQM

SCHEME:

120 K.L OHBR

25.00M Staging

Sailaja
AEE

Por
DEE

Y.S.
EE

//Approved//

[Signature]
Chief Engineer-II
RWS&S, Gollapudi
Vijayawada.

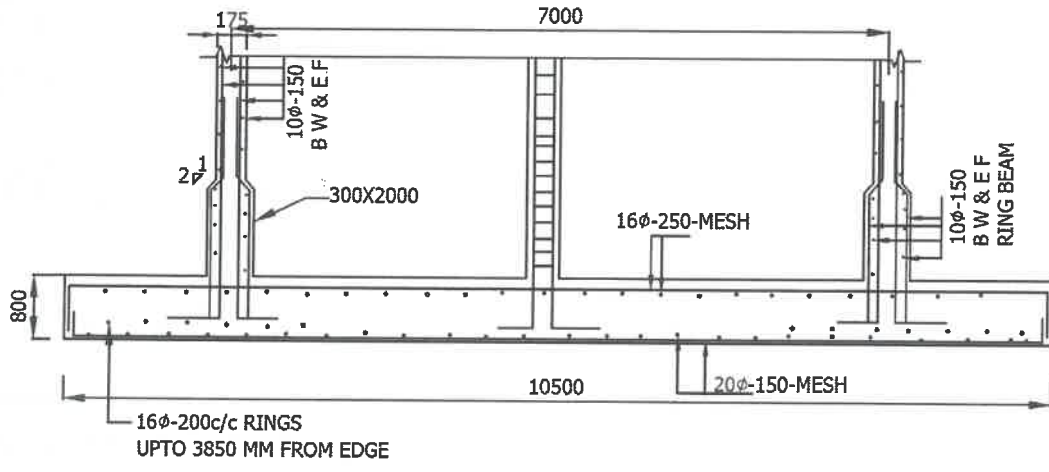

SECTIONAL ELEVATION

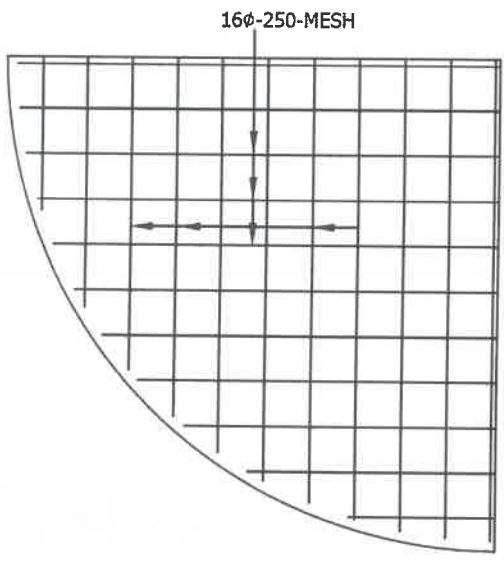

TOP REINFORCEMENT

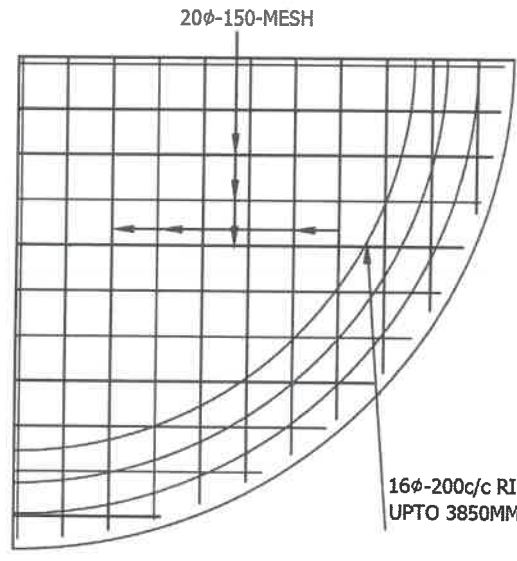

BOTTOM REINFORCEMENT

NOTE:

- 1.GRADE OF CONCRETE : M30
- 2.GRADE OF STEEL : Fe415
3. BASIC WIND SPEED : 150KMPH
- 4.DEPTH OF FOUNDATION:2.50m BELOW GROUND LEVEL UPTO TOP OF RAFT
- 5.ALL DIMENSIONS ARE IN "MM"
6. S B C OF SOILL-10T/SQM

Saijya
AEE

Poe
DEE

y.Sj
EE

//Approved//
[Signature]
Chief Engineer-II
RWS&S,Gollapudi
Vijayawada.

SCHEME:
120 K.L OHBR
25.00M Staging

543

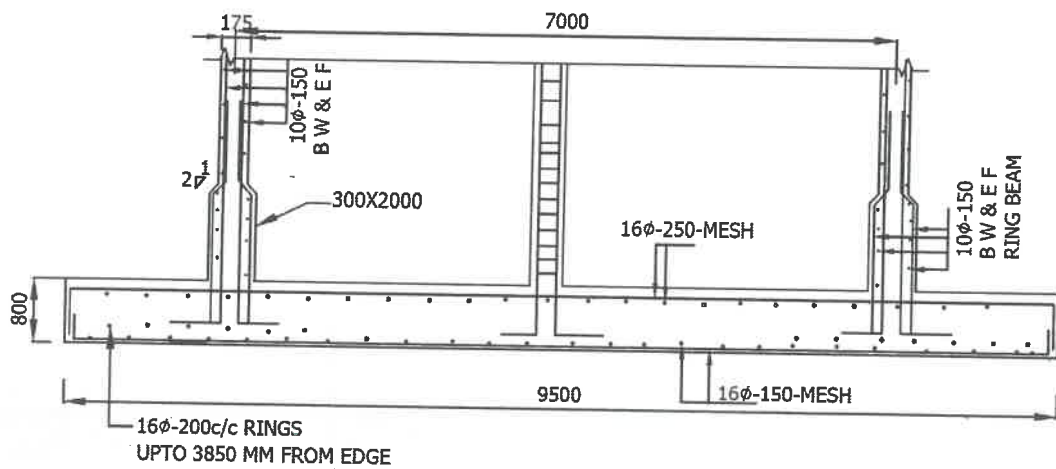

SECTIONAL ELEVATION

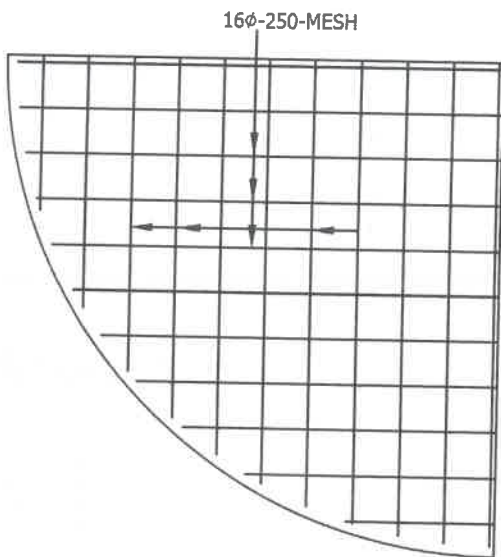

TOP REINFORCEMENT

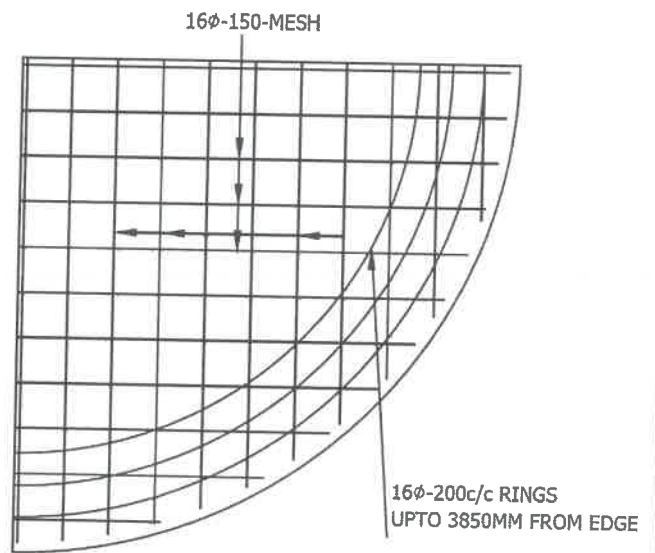

BOTTOM REINFORCEMENT

NOTE:

1. GRADE OF CONCRETE : M30
2. GRADE OF STEEL : Fe415
3. BASIC WIND SPEED : 150KMPH
4. DEPTH OF FOUNDATION: 2.50m BELOW GROUND LEVEL UPTO TOP OF RAFT
5. ALL DIMENSIONS ARE IN "MM"
6. S B C OF SOILL-15T/SQM

Sailaja
AEE

POR
DEE

Y-S
EE

//Approved//
P. K. V.
Chief Engineer-II
RWS&S, Gollapudi
Vijayawada.

SCHEME:

120 K.L OHBR

25.00M Staging

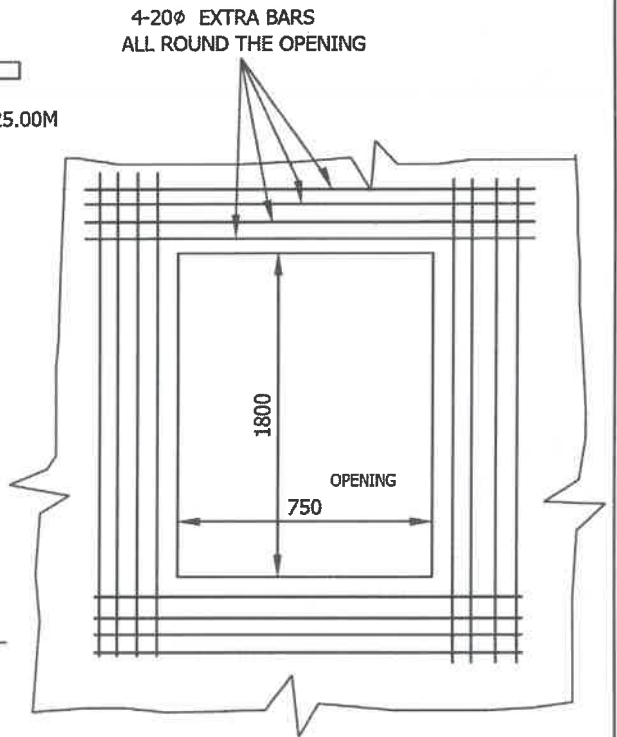
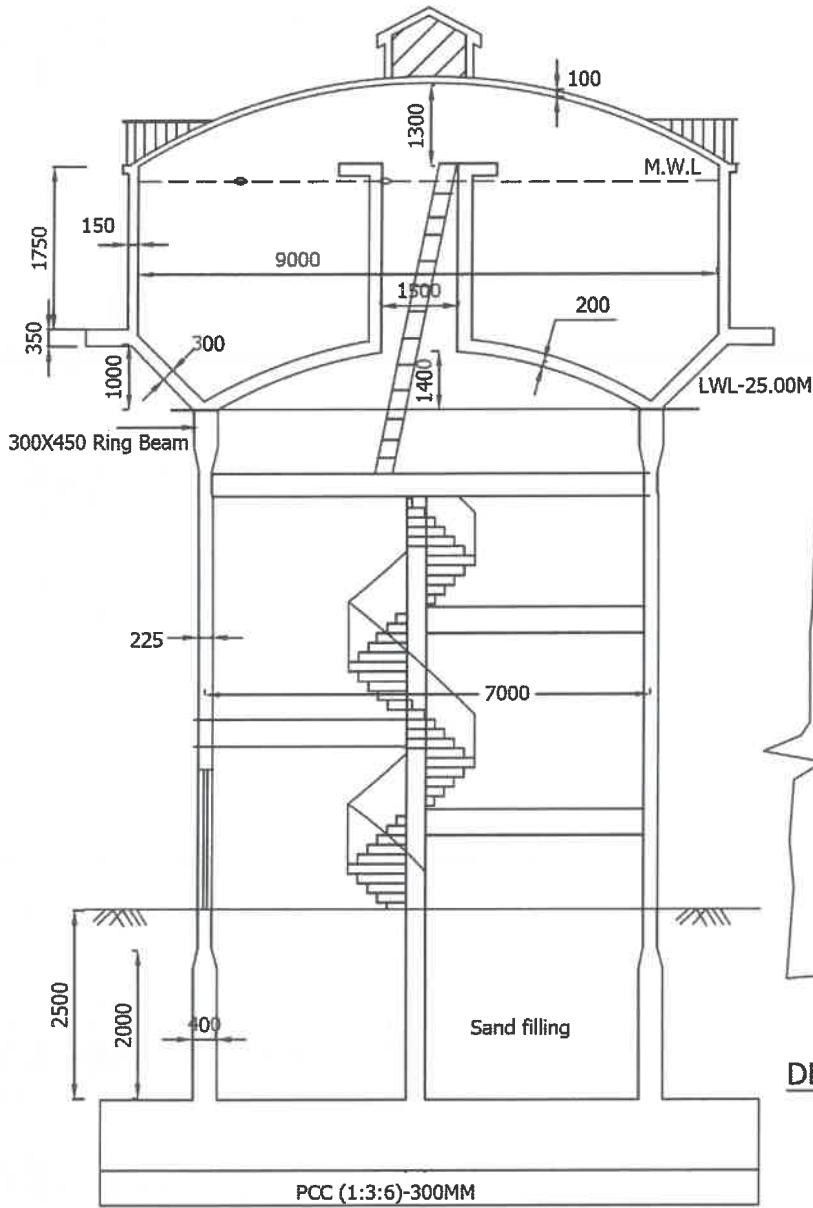

DETAILS AT THE OPENING OF SHAFT

Basic Wind speed-200 kmph

Sailyji
AEE

Por
DEE

Y-S
EE

//Approved//

[Signature]
Chief Engineer-II
RWS&S, Gollapudi
Vijayawada.

SCHEME:

120 K.L OHBR

25.00M Staging

545

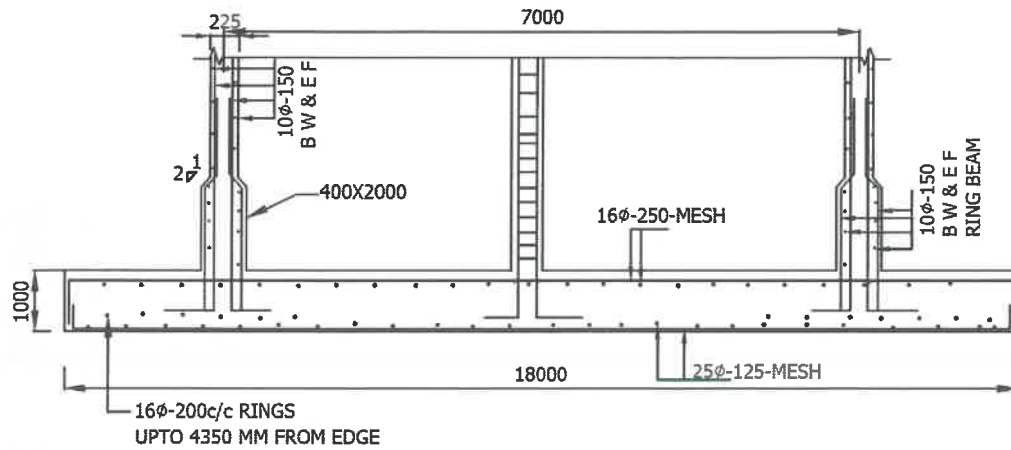

SECTIONAL ELEVATION

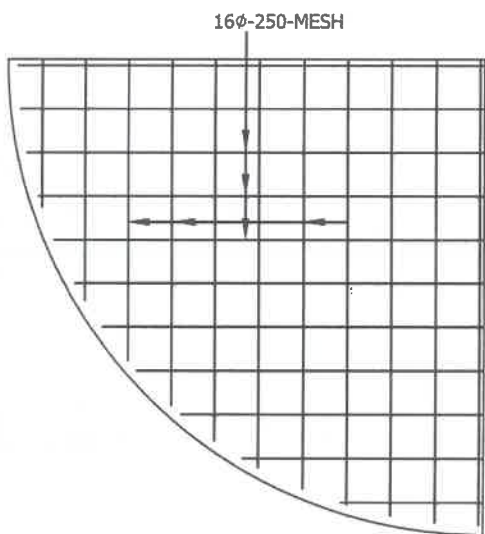

TOP REINFORCEMENT

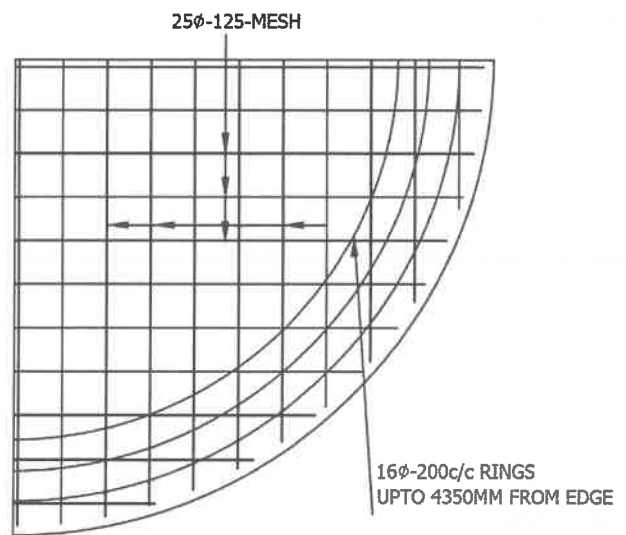

BOTTOM REINFORCEMENT

NOTE:

1. GRADE OF CONCRETE : M30
2. GRADE OF STEEL : Fe415
3. BASIC WIND SPEED : 200KMPH
4. DEPTH OF FOUNDATION: 2.50m BELOW GROUND LEVEL UPTO TOP OF RAFT
5. ALL DIMENSIONS ARE IN "MM"
6. S B C OF SOILL-5 T/SQM

Santhosh
AEE

Por
DEE

Y.S
EE

//Approved//

P. Sridhar
Chief Engineer-II
RWS&S, Gollapudi
Vijayawada.

SCHEME:

120 K.L OHBR

25.00M Staging

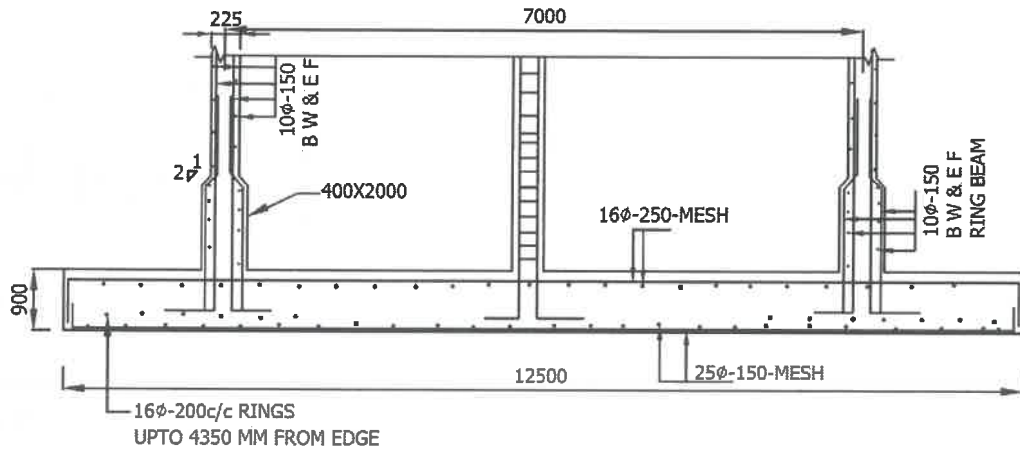

SECTIONAL ELEVATION

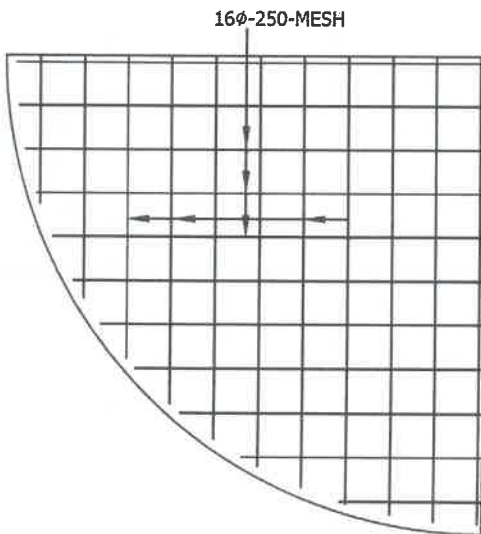

TOP REINFORCEMENT

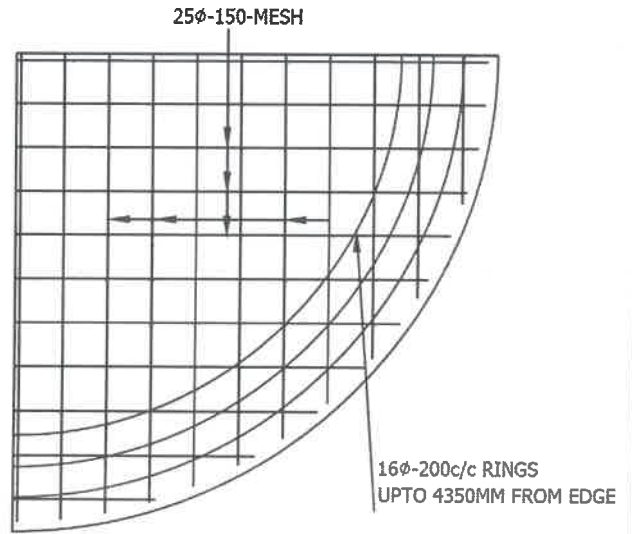

BOTTOM REINFORCEMENT

NOTE:

1. GRADE OF CONCRETE : M30
2. GRADE OF STEEL : Fe415
3. BASIC WIND SPEED : 200KMPH
4. DEPTH OF FOUNDATION: 2.50m BELOW GROUND LEVEL UPTO TOP OF RAFT
5. ALL DIMENSIONS ARE IN "MM"
6. S B C OF SOILL-10 T/SQM

Sailaja
AEE

Pur
DEE

Y.S
EE

//Approved//

[Signature]
Chief Engineer-II
RWS&S, Gollapudi
Vijayawada.

SCHEME:

120 K.L OHBR

25.00M Staging

547

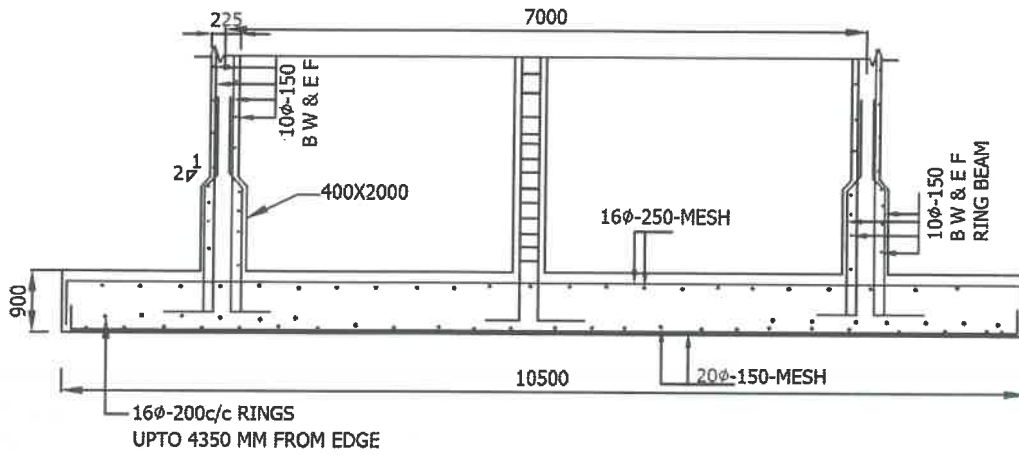

SECTIONAL ELEVATION

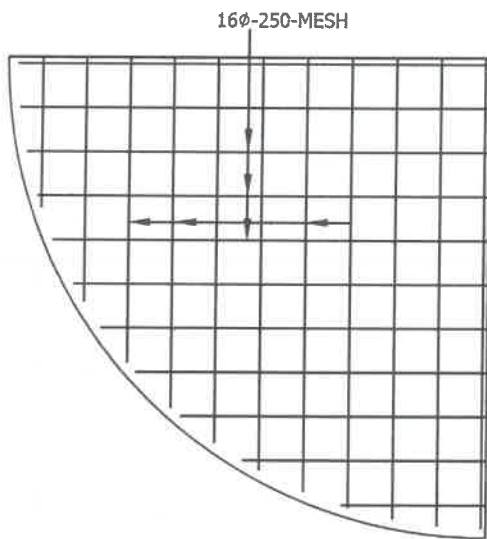

TOP REINFORCEMENT

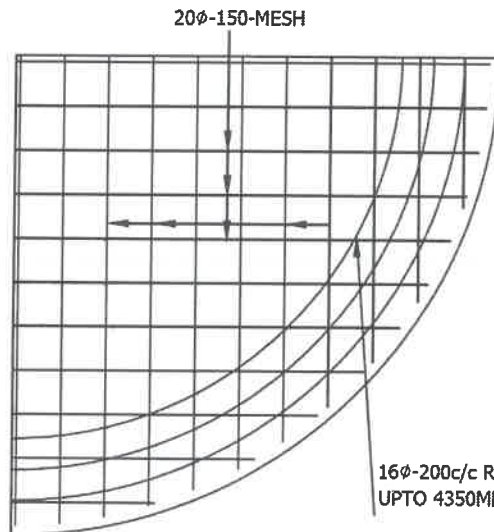

BOTTOM REINFORCEMENT

NOTE:

1. GRADE OF CONCRETE : M30
2. GRADE OF STEEL : Fe415
3. BASIC WIND SPEED : 200KMPH
4. DEPTH OF FOUNDATION: 2.50m BELOW GROUND LEVEL UPTO TOP OF RAFT
5. ALL DIMENSIONS ARE IN "MM"
6. S B C OF SOILL-15 T/SQM

Sailaja
AEE

Pop
DEE

Y.S
EE

//Approved//
[Signature]
Chief Engineer-II
RWS&S, Gollapudi
Vijayawada.

SCHEME:

120 K.L OHBR

25.00M Staging

548